



IMPORTANT SAFETY INSTRUCTIONS:

When you use an electrical appliance, basic safety precautions should always be adhered to as follows: Read all instructions before using this sewing machine. Notes on safety for household sewing machines according to IEC/EN 60335-2-28.

DANGER - To reduce the risk of electric shock:

1. A sewing machine should never be left unattended when plugged in. Always unplug this sewing machine from the electric outlet immediately after using and before cleaning.
2. To avoid electrical shock never put the machine or the mains cable or mains plug into water or other liquids.

WARNING- to reduce the risk of burns, fire, electric shock , or injury to persons:

1. This sewing machine is not intended for use by persons (including children) with reduced physical, sensory or mental capabilities, or lack of experience and knowledge, unless they have been given supervision or instruction concerning use of the sewing machine by a person responsible for their safety.
2. Children should be supervised to ensure that they do not play with the sewing machine.
3. Use this sewing machine only for its intended use as described in this manual. Use only attachments recommended by the manufacturer as contained in this manual.
4. The user must exercise adequate caution with regard to the up and down moving of the needle and constantly observe the sewing area during work.
5. When leaving the machine, during maintenance work or when changing mechanical parts or accessories, always disconnect the machine by pulling out the main plug.
6. The tension of the drive belt must only be adjusted by a specialist mechanic.
7. The machine must be put into operation according to the indications on the specification plate.
8. Never drop or insert any object into the any opening.
9. Do not use the sewing machine if:
 - a. there is a visible damage,
 - b. its function is disturbed,
 - c. it is wet, e.g. with condensation.
 - d. where aerosol spray products or oxygen is being administered.
 - e. in outdoors.
10. Never operate this sewing machine if it has a damaged cord or plug, if it is not working properly, if it has been dropped or damaged, or dropped into water. Return the sewing machine to the nearest authorized dealer or service center for examination, repair, electrical or mechanical adjustment.
11. To disconnect the sewing machine , turn the on/off switch to off ("O") position, then remove plug from outlet.
12. Do not unplug by pulling on cord. To unplug, grasp the plug, not the cord.
13. Switch off or unplug the appliance when leaving it unattended, or making any adjustments in the needle area, such as threading needle, changing needle, threading bobbin , or replacing presser foot and bulb and before carrying out maintenance.
14. If this appliance is used for another purpose than intended or if it is wrongly operated, we will not accept any liability for any damage caused.
15. To avoid the risk of electric shock, do not open the machine. There are no parts inside the machine which the user can repair. This is solely the responsibility of our qualified service staff.

16. Be sure to use only original parts.
17. Keep fingers away from all moving parts. Special care is required around the sewing machine needle.
18. Do not use bent needles.
19. Do not pull or push fabric while stitching. It may deflect the needle causing it to break.
20. Never sew with a damaged needle plate as this can cause needle to break .
21. This sewing machine is designed for mains supply with a nominal voltage of $\pm 10\%$ and a rated frequency of $\pm 4\%$.
22. If the power plug or power cords damage, it must be replaced by the Manufacturer or it's service agent or a similarly qualified person.
23. Attention the following to avoid injury:
 - a. Unplug the foot controller of the appliance when leaving it unattended.
 - b. Unplug the foot controller of the appliance before carrying out any maintenance.
24. The LED lamp maximum power is 3 W, if the LED lamp is damaged , you should not use the sewing machine and send it to the manufacture or service agent to repair or replace it.
25. This sewing machine uses the foot control model HKT72C or FL3902.

Environment:

The recommended environment is

- Ambient temperature 20°C to 30°C
- Humidity 20% to 80%.
- Storage temperature - 25°C to + 60°C

This sewing machine is a high-quality electronic-mechanical appliance; it is a machine for supervised use at home. It should be operated in such a way that it is not subjected to: dust, severe dampness, direct sunlight, static electricity, heat - producing object, corrosive chemicals or liquids.

For ventilation purposes the machine must be used on a free surface, which is both firm and even.

This sewing machine is a suppressed and immune to interference ;however , it should not be operated near electronic devices such as radios, TVs, PCs, broadcasting transmitters etc.

Care of the sewing machine:

Always protect the machine against damage which might occur by hitting or dropping.

Cleaning:

Housing: To clean the housing, use a dry, clean and soft cloth which is free of fluff. To remove any of stubborn dirt, use a soft cloth with alcohol .

Please note!

Do not use any insecticides or chemical products such as petrol (gasoline) or thin chemicals for cleaning the housing.

Run this appliance for at least 2 minutes before actual sewing.

This equipment is marked with the recycling symbol. Do not dispose this product as unsorted municipal waste. Collection of such waste separately for special treatment is necessary. If in doubt please contact your retailer for guidance. (European Union only)



Disposal

SAVE THESE INSTRUCTIONS

Congratulations!

As the owner of a new sewing machine Gritzner Varimatic 935, you will enjoy precision quality stitching on all types of fabrics, from multiple layers of denim to delicate silks.

Your sewing machine offers the ultimate in simplicity and ease of operation. For your safety and to fully enjoy the many advantages and ease of operation of your sewing machine, we recommend that you read all the important safeguards and use and care instructions in this instruction book.

May we suggest that before you start to use your sewing machine, you discover the many features and advantages by going through this instruction book, step by step, while seated at your sewing machine..

Contents:	Page:
Parts of your sewing machine	4
Accessories	5
Remove and installing the removable extension table	6
Connecting machine to power source	7
Presser bar lifter	8
Darning plate	8
Removing and setting the presser foot	9
Fitting the edge guide	9
Winding the bobbin	10
Inserting the bobbin into the shuttle	11
Inserting and changing needle	12
Threading the upper thread	13
Automatic needle threader	14
Dual Feed Transporter/ DFT system	15
Thread tension	16
Raising the bobbin thread	17
Reverse sewing	18
Removing the work	18
Cutting the thread	18
Selection guide table of needle and fabric and thread	19
Selection table of needle and fabric	20
How to choose your pattern	21
Straight stitch	22
Zigzag stitch	23
Triple stitch	24
Honeycomb stitch	25
Blind hem stitch	26
Button sewing	27
Buttonholes sewing	28
Sewing on zipper	29
Sewing with the hemmer foot	30
3 steps zigzag stitch	31
Darning	32
Decorative stitches	33
Couching	34
Twin needle	35
Monogramming and embroidering with embroidery hoop	36
Maintenance	38
Trouble shooting guide	39

Parts of your sewing machine:

1. Needle tension dial
2. Take-up lever
3. Bobbin winder thread cpl.
4. Face plate
5. Thread cutter
6. Needle threader
7. Presser foot
8. Needle plate
9. Sewing table and accessory box
10. Reverse sewing lever
11. Stitch display
12. Bobbin winder stoper
13. Bobbin winder spindle
14. Stitch length dial
15. Stitch width dial

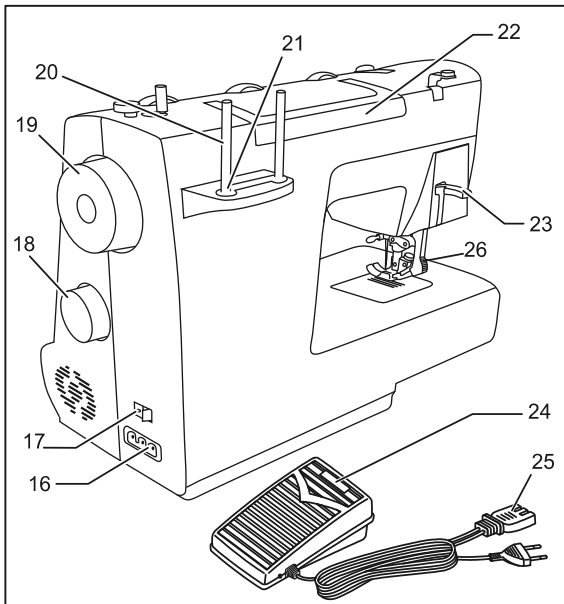
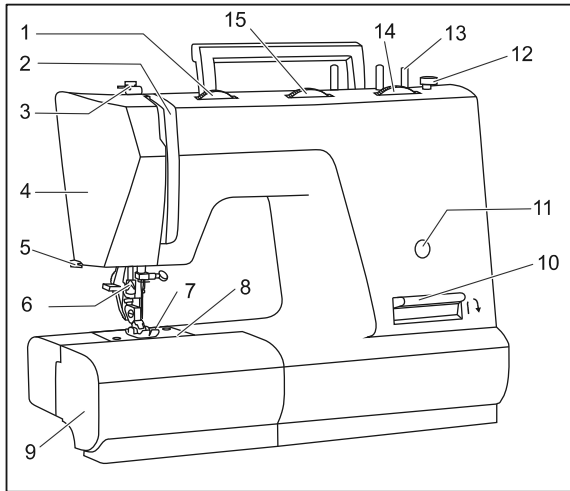

16. Main plug socket
17. Main power switch
18. Pattern selector dial
19. Handwheel
20. Spool pin
21. Spool pin cap (Spool holder)
22. Handle
23. Presser foot lifter
24. Foot control
25. Socket
26. DFT-System (Dual feed transporter)

Accessories:

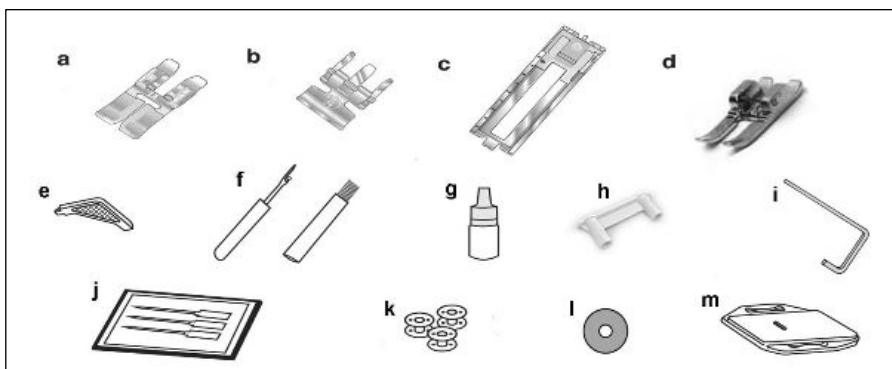

The following accessories are supplied with this machine.

- | | | |
|-------------------------|---------------------------------|-----------------------|
| a. Standard sewing foot | b. Zipper foot | c. Buttonhole foot |
| d. Applique foot | e. L-screwdriver | f. Seam ripper/ brush |
| g. Oil bottle | h. Spool pin cap (Spool holder) | i. Edge guide |
| j. Pack of needle | k. Bobbin(3x) | l. Spool pin felt |
| | | m. Darning plate |

Optionales accessories:

The optionales accessories are intended for special sewing jobs. They can be obtained from your dealer at an extra charge.

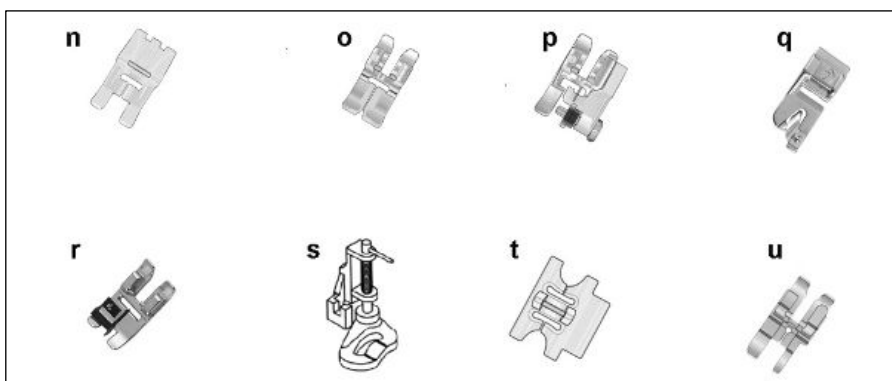

- | | |
|--|--|
| n. Clear view foot | o. Fancy stitch foot for D.F.T System |
| p. Blind stitch foot for D.F.T System | q. Hemmer foot |
| r. Narrow edge foot for D.F.T System | s. Darning foot for D.F.T System |
| t. Pintuck foot with decorative stitch guide | u. 1/4 inch quilting foot for D.F.T System |

Remove and installing the removable extension table:

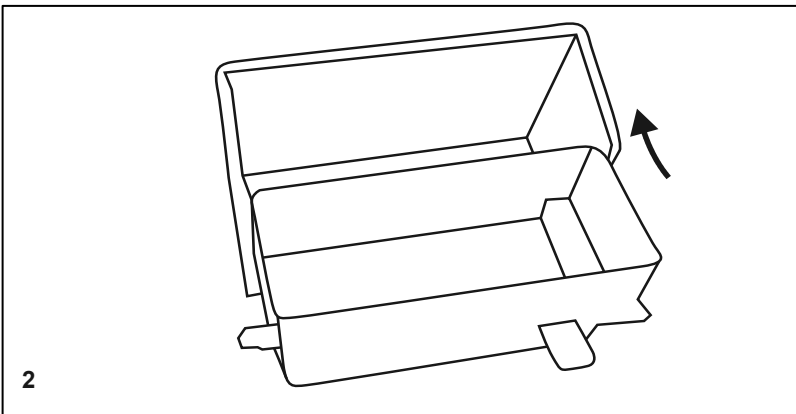
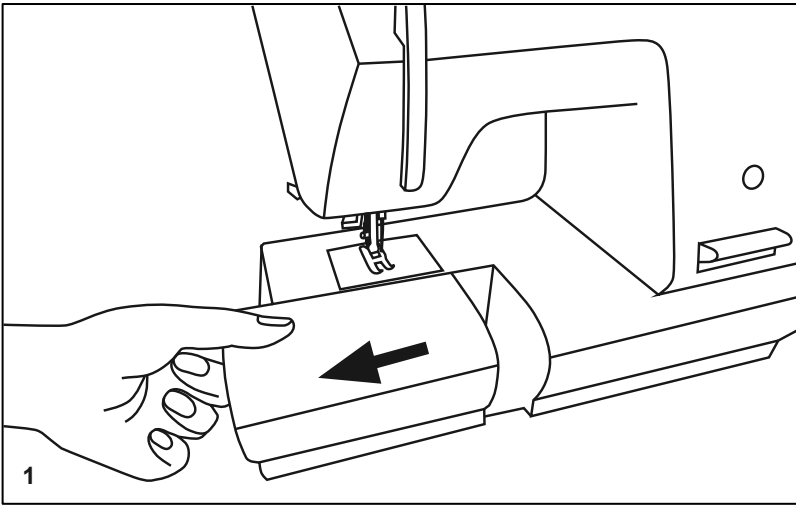

To removing the removable extension table, hold removable extension table and pull in the dirction of the arrow.(1)

To install the removable extension table, hold the removable extension table sewing table horizontal, and push it in the opposite direction of the arrow.(1)

The inside of the snap-in sewing table can be utilized as an accessory box.To open, lift up at the point of the arrow. (2).

Connecting machine to power source:

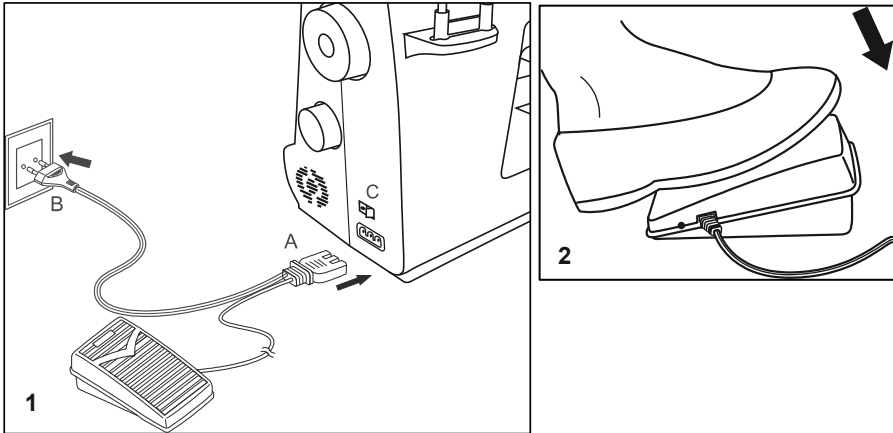

Connect the machine to a power source as illustrated. (1)

Attention:

Unplug power cord when machine is not in use.

Foot control:

Connect the plug of the foot control to the connecting socket (A) of the sewing machine and to the wall socket. The sewing speed is regulated by pressing the foot control. Make sure that you have the right type of foot control.

Attention:

- For this sewing machine foot control model HKT72C or FL3902 must be used.
- If you have problem with plug connection, give support from a qualified electrician.

Sewing light:

Your sewing machine is equipped with low consumption & long lifetime LED lamp.

Note:

There is no need to replace the LED lamp by yourself, If any problem occur with this lamp, you should not use the sewing machine anymore and send it to the nearest dealer or service center to repair & replace lamp quickly.

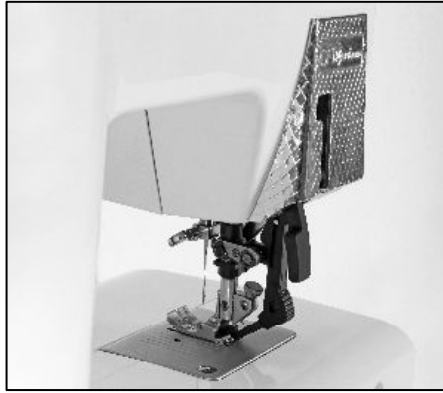
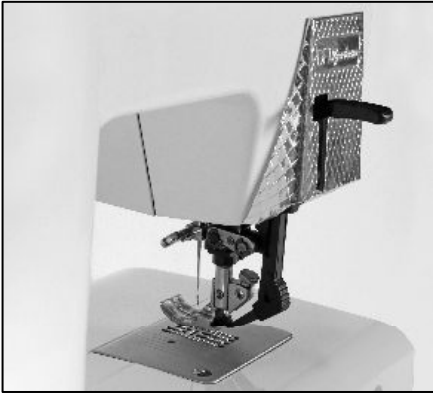

Presser bar lifter:

The presser foot is raised or lowered with the presser foot lifter. When sewing several layers or thick fabrics, the presserfoot can be raised a second stage for easy positioning of the work.

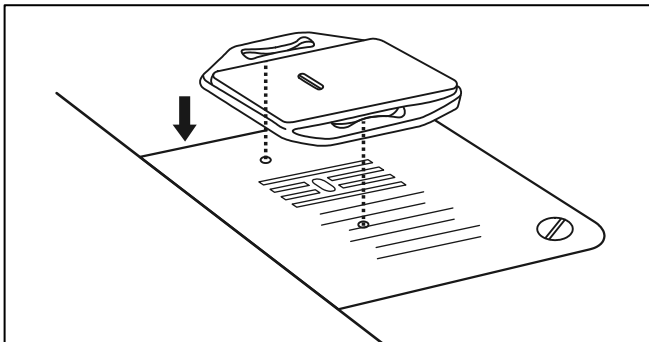

Darning plate:

For certain types of work,(e.g. darning or free-hand embroidery), the darning plate must be used.

Note:

For For normal sewing, remove the darning plate.



Before changing the presser foot and setting up the presser foot, the main switch must be switched off ("O").

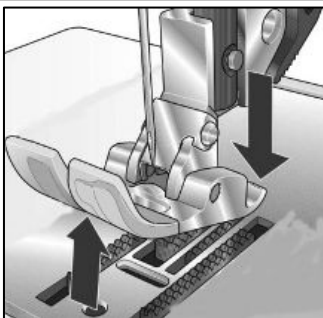
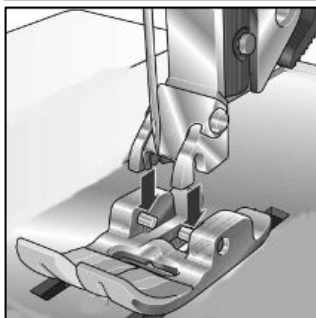

Removing the presser foot:

Position the needle at its highest point.

Press the presser foot upwards at the front and down at the back at the same time so that it disengages from the presser foot holder.

Setting the presser foot:

Place the presser foot under the presser foot holder so that when the presser foot lifter is lowered, the pins of the foot engage in the presser foot holder.

Check: Please check that the presser foot is properly engaged by raising the presser foot lifter.

Important:

After fitting the foot in its place, by moving the presser bar lifter up/down, make sure that the foot has been inserted correctly.

Dear customer:

We recommend to use only standard sewing feet, if not, it will cause needle breakage or other damages. You can obtain the standard sewing feet only from authorized dealers.

Fitting the edge guide:

Push edge guide "N" through hole "A" and secure it in position with screw "B". The guide can be adjusted to the desired stitching margin for various applications.

With attached edge guide, it is easy to sew parallel lines of stitches or to stitch parallel to the edge. The guide either following an edge (Fig. Q) or, when making parallel lines of stitches, run along the preceding line of stitches. The seam thus looks more neat and accurate.

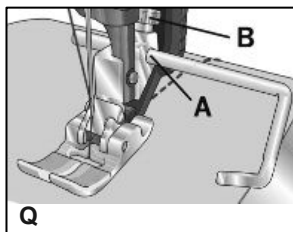
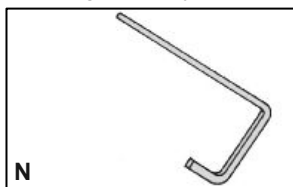

Winding the bobbin:

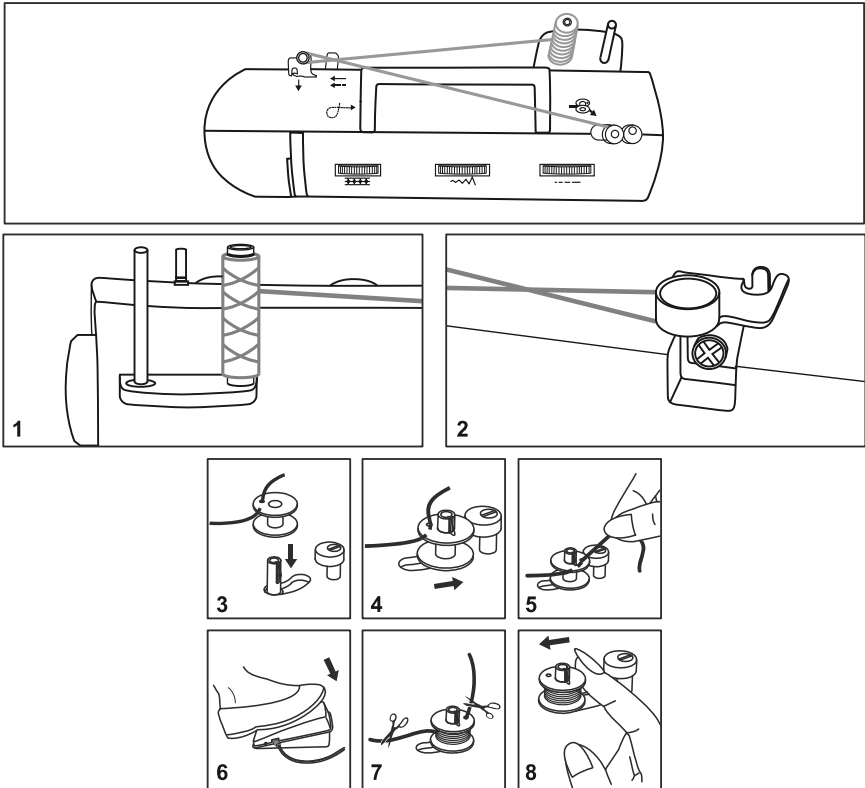

- Place thread onto spool pin and press the spool holder firmly against the spool pin. (1)
- Wind thread clockwise around bobbin winder tension discs.(2)
- Thread bobbin as illustrated and place on bobbin winder spindle. (3)
- Push bobbin to right. (4)
- Hold thread end of thread firmly. (5)
- Press the foot control, the winding action will stop automatically as soon as the bobbin is full. (6)
- Cut the thread . (7)
- Push bobbin winder spindle to the left and remove the full bobbin. (8)

Please note:

When the bobbin winder spindle is in bobbin winding position, the machine will not sew and the hand wheel will not turn. To start sewing, push the bobbin winder spindle to the left (sewing position).

Inserting the bobbin into the shuttle:



turn main switch off "O" before inserting or removing the bobbin.

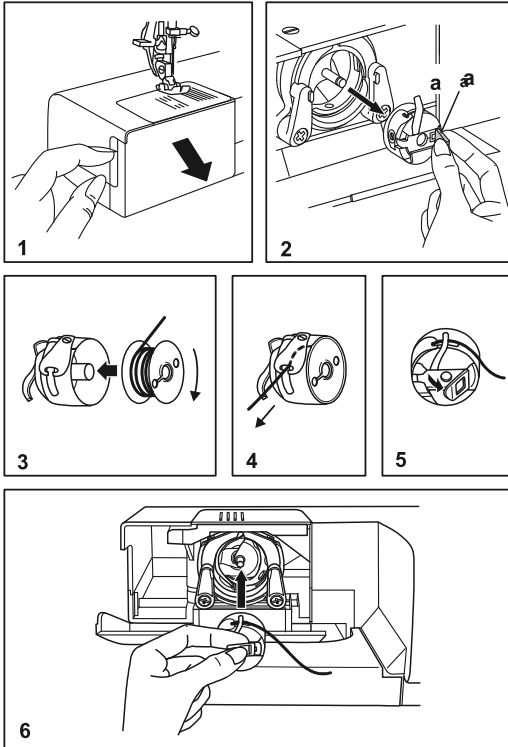

When inserting or removing the bobbin, the needle must be fully raised.

- Hold the hook cover and open it forwards. (1)
- Pull the bobbin case tab (a) and remove the bobbin case. (2)
- Hold the bobbin case with one hand. Insert the bobbin so that the thread runs in a clockwise direction (arrow). (3)
- Pull the thread through the slit and under the finger. (4)
- Hold the bobbin case by the hinged latch. (5)
- Insert it into the shuttle. (6)

Check:

Pull the bobbin tread sharply. The bobbin case must not fall out of the shuttle.

Inserting and changing needle:



Turn main switch off "O" before inserting and changing needle.

Change the needle regularly, especially if it is showing signs of wear and causing problems. Please always use good quality needle available in the market which it presented by your dealer.

To remove the needle: Lower the presser foot and move the needle to its highest point. Now loosen the needle screw (A) and pull the needle (C) downwards.

To insert the needle: The flat side of needle shaft (B) should be to the rear. Lower the presser foot and insert the needle, pushing it up as far as it goes. Hold the needle and tighten the needle screw firmly. Needle must be in perfect condition. (2)

Problem can occur with:

- A. Bent needles
- B. Damage points
- C. Blunt needles

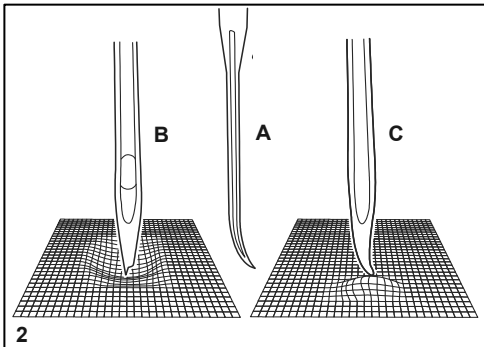
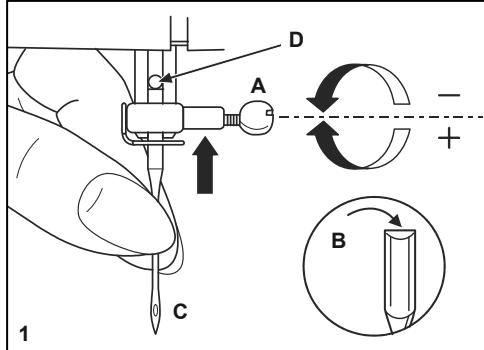

To check for a good needle:

Put the flat side of the needle onto something flat (needle plate, glass etc.)
The gap between the needle and the flat surface should be consistent.
Never use a bent or blunt needle.

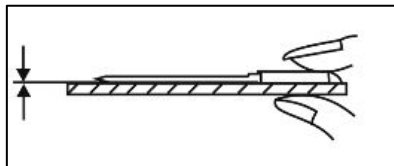

Note:

Check the needle frequently for barbed or blunted points..

Threading the upper thread:



Turn main switch off "O" before threading the upper thread.

This is simple is operation but if does not perform correctly, so many sewing problems could result.

- start by raising the needle to its highest point and also raise the presser foot to release the tension discs .(1)
- Place thread on spool pin and press the spool holder firmly on the spool pin. (2)
- Draw thread from spool and pass it through upper thread guide . (3)
- Pull the thread down through right threading slot of thread tension and then direct it left and take it up from left slot of thread tension (4), during this process it is helpful to hold the thread between the spool and thread guide(3).
- Firmly pull the thread from right to left through the slotted eye of the take-up lever and then downwards again.(5)
- Now pass thread through the needle clamp guide (6) and then down to the needle which should be threaded from front to back.
- Pull about 10 cm of thread to the rear of the needle eye. Cut the extra thread length by thread cutter. (7)

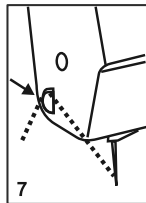
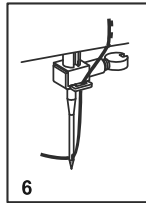
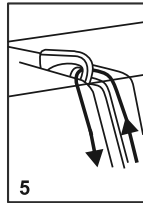
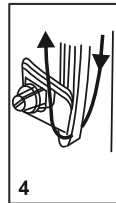
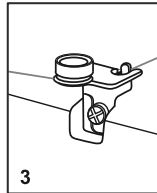
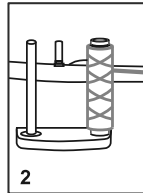
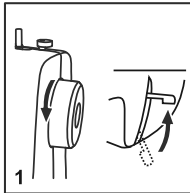
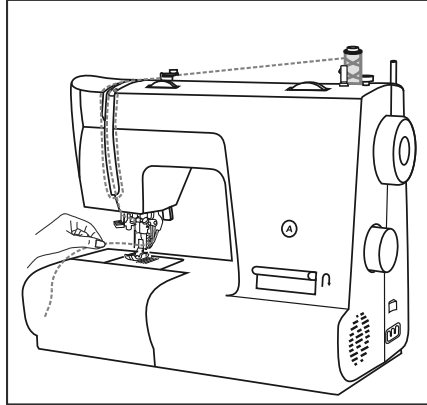

Notes:

- Always thread the needle from the front.
- Always use good quality threads available in the market, in order to obtain the best results.

Automatic needle threader:



Turn main switch off "O" before threading the needle with automatic needle threader.

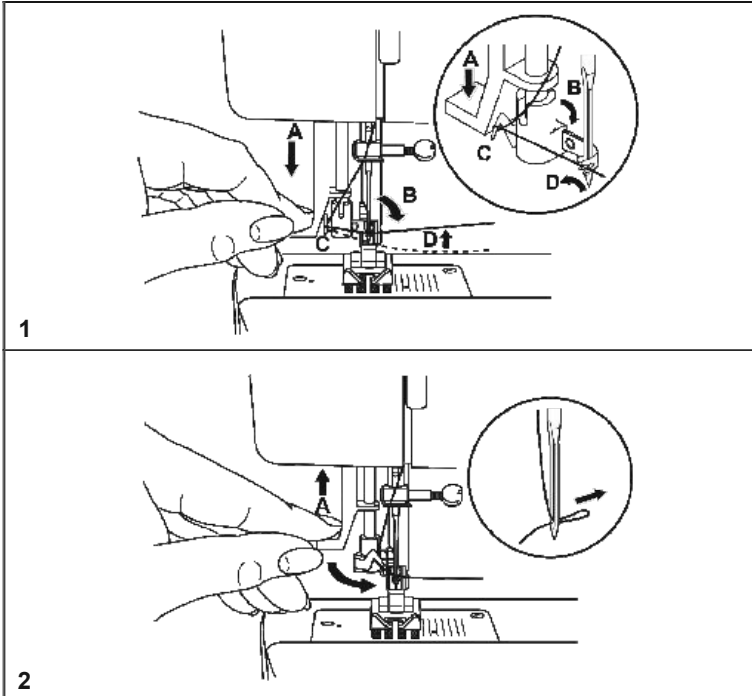

- Raise the needle to its highest position.
- Raise the presser foot.
- Push the lever (A) down as far as it will go.
- The threader automatically swings to the threading position (B).
- Take the thread around the hook (C).
- Take the thread in front of the needle around hook (D) from bottom to top .
- Release lever (A).
- Pull the thread through the needle eye.

Notes:

- All models are not equipped with an automatic needle threader.
- The automatic needle threader cannot be used with a twin needle.

Dual Feed Transporter/ DFT system:

We offer the ideal solution for sewing difficult material: Dual Feed Transporter. This system feeds the material from the top and bottom simultaneously as is done in industrial sewing machines. The fabric is fed precisely. When sewing light or heavy material such as silk and rayon fabrics, the dual feed prevents seam puckering. The even feeding action also ensures perfect matching of checked and striped fabrics.



Engaging the Dual Feed Transporter:

Important: For all sewing jobs with the top feed, only use sewing feet which is cut out at the back. Raise the presser foot. Then push the top feed downwards until it snaps into its place.



Disengaging Dual Feed Transporter:

Hold the dual feed with two fingers at the marked places. Push the top feed down a little and out to the rear, and let it move slowly upwards.



Thread tension:

Upper needle thread tension (Figure 1):

- For the best stitch appearance and durability, make sure the needle thread tension is correctly adjusted. For general sewing, the threads evenly meet between the two layers of fabric
- The normal setting for utility stitches is in the range 4-5.
- To increase the tension, turn the dial to the next number up.
- To reduce the tension, turn the dial to the next number down.

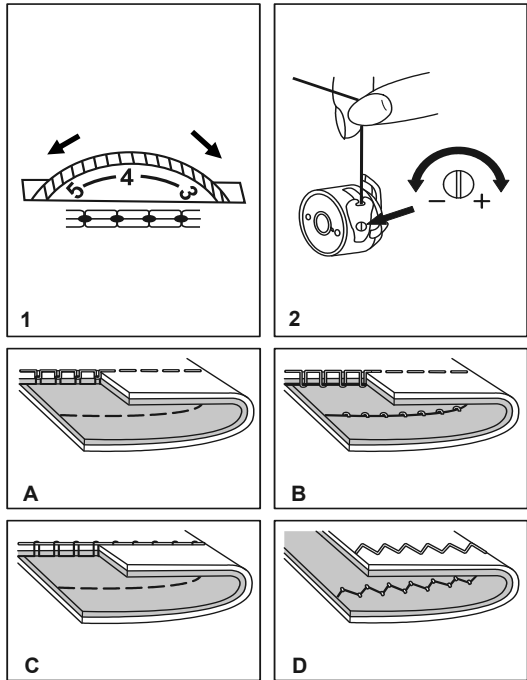

Figures:

- A. Normal thread tension for straight stitch sewing.
- B. Thread tension is too loose for straight stitch sewing. Turn dial to higher number.
- C. Thread tension is too tight for straight stitch sewing. Turn dial to lower number.
- D. Normal thread tension for zigzag and decorative sewing.

Note:

To obtain better zigzag and decorative stitches, the upper tension should be slightly weaker than in the case of straight sewing, thus the upper thread appears slightly on the bottom side of fabric.

Lower needle thread tension (Figure 2):

To check the bobbin thread tension, remove the bobbin case and bobbin and hold it by suspending it by the thread. Jerk it once or twice. If the tension is correct, the bobbin thread will unwind by about 2.5 to 5 cm downward.

- If the tension is too tight, turn the small screw on the bobbin case slightly counter-clockwise.
- If the tension is too loose, turn the small screw on the bobbin case slightly clockwise.

Note:

The bobbin thread tension does not normally have to be adjusted.

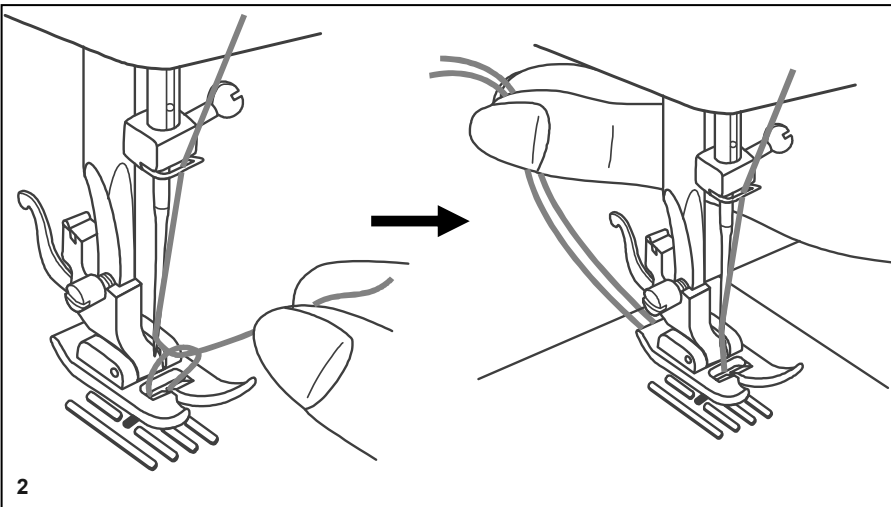
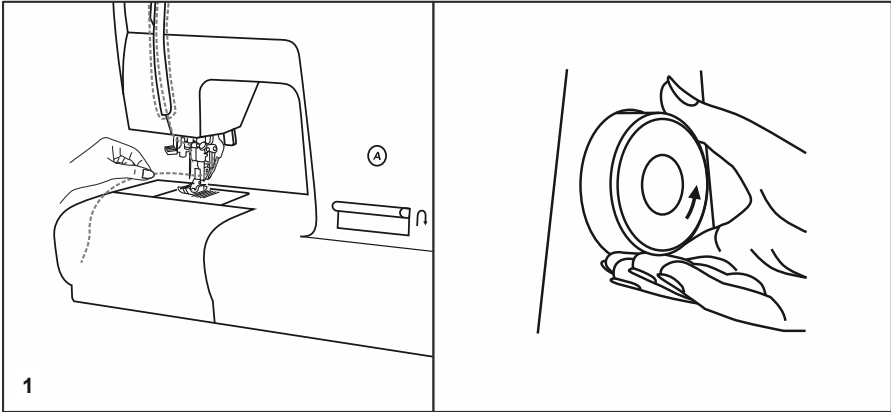

Raising the bobbin thread:

Hold the upper thread with the left hand. Turn the handwheel towards you (counterclockwise) lowering, then raising needle (1).

Pull on the upper thread to bring the bobbin thread up through the needle plate hole. Now pull both threads back under the presser foot approx. 15 cm (2).

Reverse sewing:

To secure the beginning and the end of a seam, press down the reverse sewing lever (A). Sew a few reverse stitches. Release the lever and the machine will sew forwards again. At the end of the sew, repeat this process. (1)

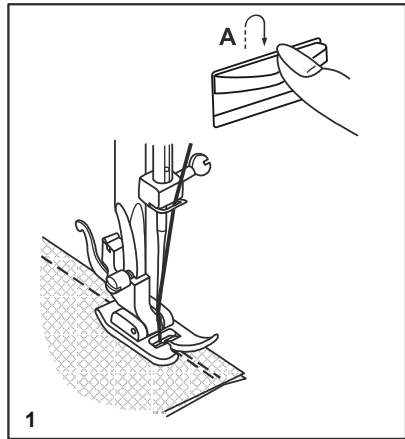

Removing the work:

Turn the handwheel towards (counterclockwise) to bring the thread take up lever to its highest position, raise the presser foot and remove work behind the needle and presser foot. (2)

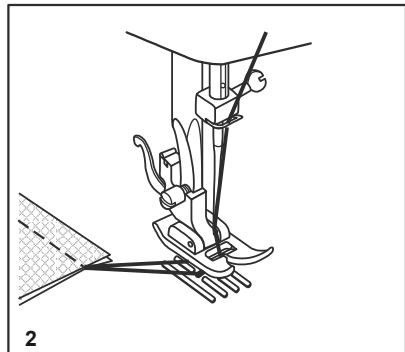

Cutting the thread:

Pull the threads under and behind the presser foot with both hands, guide the threads to the side of the face plate and into the slit (B). Pull threads down to cut. (3)

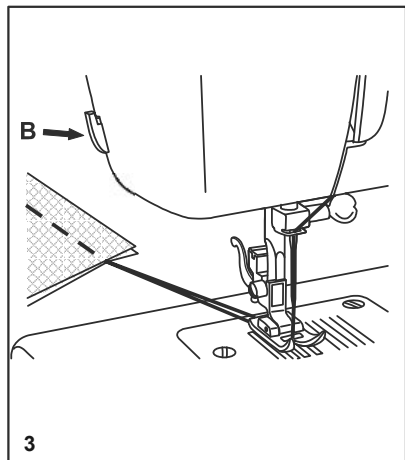

Selection guide table of needle and fabric and thread:

Needle size	Fabrics	Thread
65-75(9-11)	Lightweight fabrics: Thin cottons, voile, serge, silk, muslin, Liana , interlocks, cotton knits, tricot, jerseys, crepes, woven polyester, shirt & blouse fabrics.	Light-duty thread in cotton, nylon or polyester.
80(120)	Medium weight fabrics: Cotton, satin, kettleclote, sailcloth, double knits, lightweight woolens.	Most threads sold are medium size and suitable for these fabrics and needle sizes. Use polyester threads on synthetic materials and cotton on natural woven fabrics for best results. Always use the same thread on top and bottom.
90(14)	Medium weight fabrics: Cotton duck, woolen, heavier knits, terrycloth, denims.	
100(16)	Heavyweight fabrics: Canvas, woolens, outdoor tent and quilted fabrics, denims , upholstery material (light to medium).	
110(18)	Heavy woollens, overcoat fabrics, upholstery fabrics, some leathers and vinyls.	Heavy duty thread, carpet thread.

Important:

With heavier's fabric should be used the thicker's thread and larger's needle size.

Selection table of needle and fabric:

Needles	Explanation	Type of fabric
Hax1 15x1	Standard sharp needles. Sizes range thin to large.65(9) to 110(18)	Natural woven fabrics: Wool, cotton, silk, etc. Qiana. Not recommended for double knits.
15x1/705H	Semi-ball point needle, scarfed. 65(9) to 110(18)	Natural and synthetic woven fabrics, polyester blends. Knits-polyesters, interlocks, tricot, single and double knits. Can be used needle of 15x1 for sewing all fabrics.
15x1/705H (SUK)	Full ball point needle. 65(9) bis 110(18)	Sweater knits, Lycra, swimsuit fabric, elastic.
130 PCL	Leather needles. 80(12) bis 110(18)	Leather, vinyl, upholstery. (Leaves smaller hole than standard large needle)

Important notes::

1. Twin needles, can be purchased for utility and decorative work.
2. When sewing with twin needles, the stitch width dial should be set at less than "3".
3. European needles show sizes 65, 70, 80 etc. America and Japanese Needles show size 9, 11, 12 etc.
4. Replace needle often (approximately every other garment) and/or at first thread breakage or skipped stitches.

How to choose your pattern:

To select a stitch, simply turn the pattern selector dial (d) , until the desired symbol or letter appears in the stitch display (c).

Adjust the stitch length with the stitch length dial (b) according to the fabric being used.

The needle position can be selected from left to right by turning the stitch width dial (a).

For the straight stitch, turn the pattern selector dial (d), till the letter "A" in the stitch display (c) appears.

For the zigzag stitch, turn the pattern selector dial (d), till the letter "B" in the stitch display (c) appears.

For the other stitches, turn the pattern selector dial (d) until the desired symbol or letter appears in the stitch display (c). Adjust the stitch length and stitch width as required.

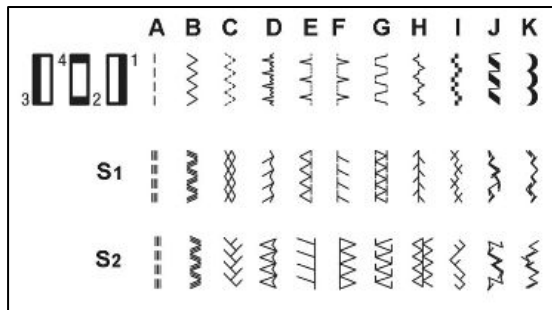
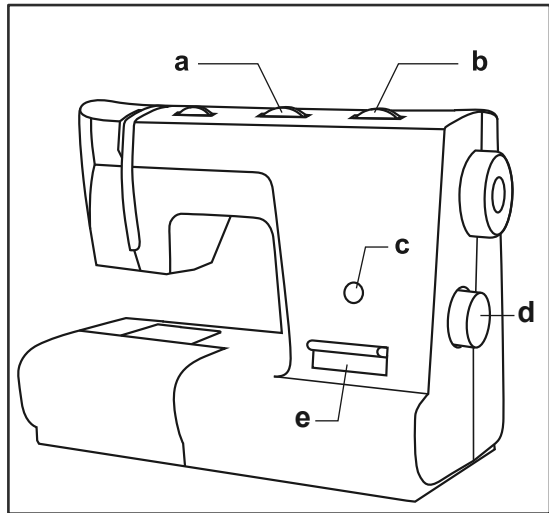

- a. Stitch width dial (for 3-dial model)
- b. Stitch length dial S1-S2
- c. Stitch display
- d. Pattern selector dial
- e. Reverse sewing lever

Straight stitch:

Turn the stitch selection dial to letter "A" appears in the stitch display (c).

The needle position for the straight stitch is also determined with the stitch width dial where "0" is the position in the left and "2.5" is in the middle and "5" is the position in the right.

If you turn the stitch length dial towards "0", the length of the respective stitch is reduced.

As you turn it in the direction of "4", the length of the selected stitch increases.

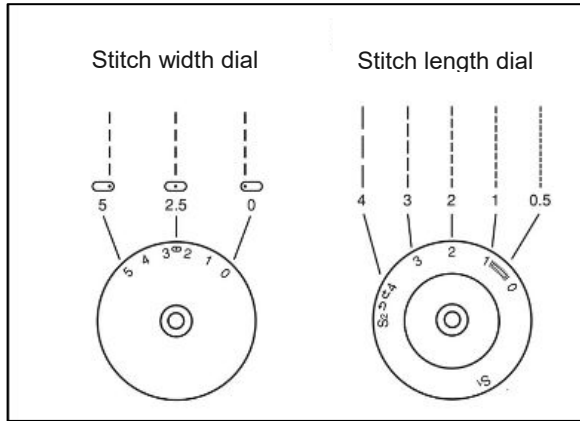

Generally speaking, the thicker the fabric and needle, the longer the stitch should be. For a fine stitch set length at "1" or "2". For gathering, set stitch length to "4". For thick fabrics, set the stitch length between "3" or "4".

Straight stitch

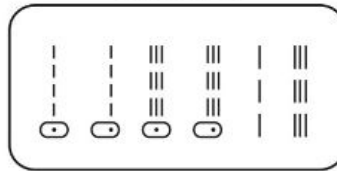

Zigzag stitch:

Function of stitch width dial:

The maximum zigzag stitch width for zigzag stitching is 5 mm, however, the width can be reduced on any patterns. The width increases as you turn stitch width dial from “0” to “5”.

For twin needle sewing, never set the width more than “3”.

With the stitch width dial can set also the needle position for the straight stitch, where “0” is the position in the left and “2.5” is in the middle and “5” is the position in the right.

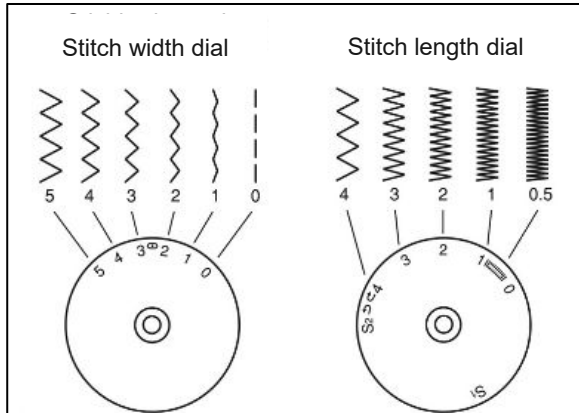

Function of Stitch length dial while zigzagging:

The density of zigzag stitches increase as the setting of stitch length dial approaches “0”.

Neat zigzag stitches are usually achieved at “2.5” or below.

Satin stitch:

When the stitch length is set between “0” – “1” , the stitches very close together producing the “satin stitch” which is used for making buttonholes and decorative stitches.

Fine fabric:

When sewing on very fine fabric, place a piece of thin paper under the fabric. It is easy to tear the paper and remove the paper after you have finish your seam.

Triple stitch:

If you want to select these stitches, you must turn the pattern selector dial to the stitch you want. Then set the stitch length dial to "S1" or "S2". There are several elastic stitches. Here are two examples:

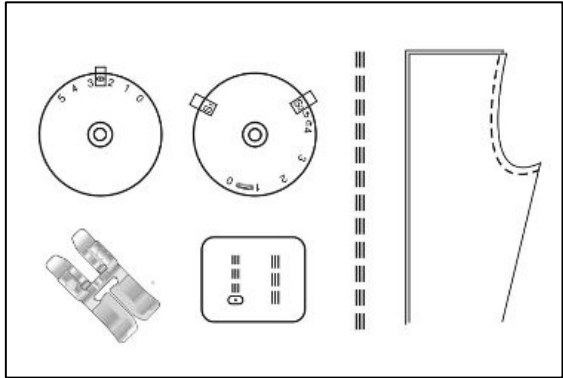

Triple straight stitch:

Turn the stitch selection dial to letter "A" appears in the stitch display (c) and turn the stitch length dial to "S1" or "S2" and stitch width dial in center needle position. This stitch is stronger than regular straight stitch, due to the fact that is a triple and elastic stitch. The machine sews two stitches forwards and one stitch backwards, forming a seam that does not rip easily.

Triple zigzag stitch:

Turn the stitch selection dial to letter "B" appears in the stitch display (c) and turn the stitch length dial to "S1" or "S2".

Adjust the stitch width dial to between "3" and "5". Triple zigzag stitch is suitable for inelastic and dense fabrics such as jeans, denim, corduroy, canvas, etc.

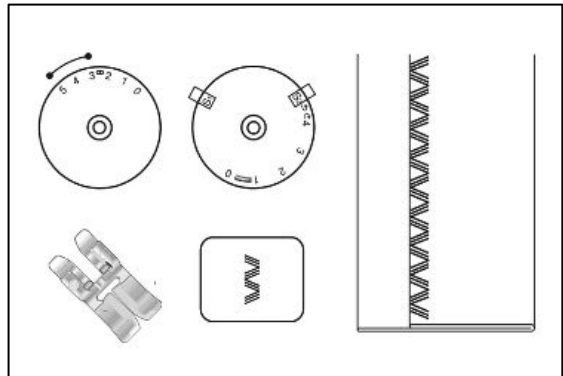

Honeycomb stitch:

Turn the stitch selection dial to letter “C” appears in the stitch display and turn the stitch length dial to “S1”.

To sew the honeycomb, adjust the stitch width dial between “3” and “5”.

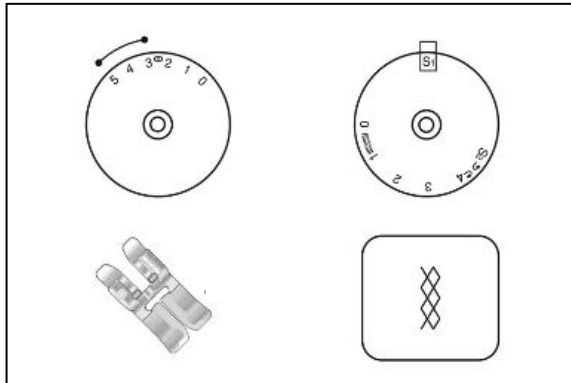

The honeycomb stitch is an elastic and decorative hem which is particularly suitable for different types of jersey (tricot) as well as for woven fabrics and hems on T-shirts and children clothes. (1)

Sew at 1cm from the fabric edge and trim the surplus fabric. (2)

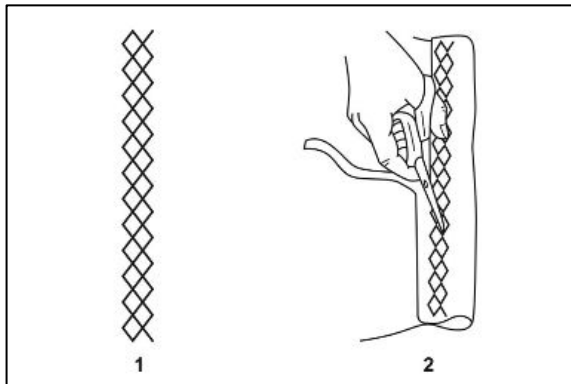

Blind hem stitch:

The blind hem stitch is used to make invisible hems on hems, curtains, trousers, skirts, etc..

 Blind hem for stretch fabrics..

 Blind hem / lingerie for firm fabrics.

- Insert the blind stitch foot and Set the machine as illustrated. (1)
- Fold the fabric as illustrated with the wrong side uppermost. (2)
- Fold the hem back on itself so approximately 1cm of finished edge extends beyond the fold. The wrong side of your project should now be facing up. (3)
- Place the fabric under the presser foot so that the fold runs along edge guide (4).
- When the needle swings into the fold it should catch a small amount of fabric. If the stitches are visible on the right side, adjust the edge guide (4) by turning adjust screw (5) until the stitch that catches the hem just barely shows.
- To get a perfect blind stitch, we recommend that you press the foot control slowly.

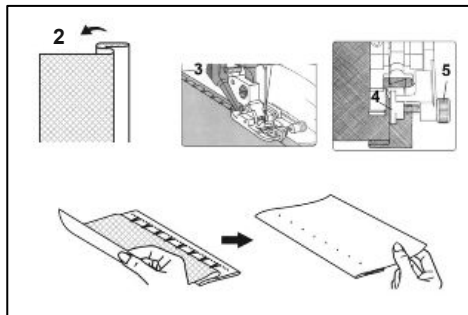
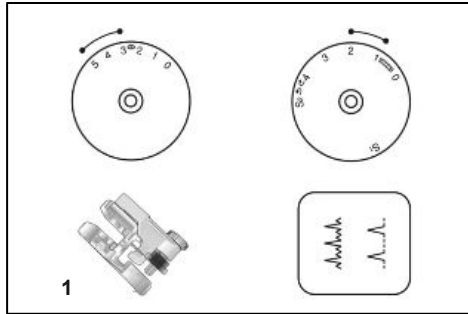

Notes:

1. For a perfect blind stitch a lot of practice is need, therefore before you sew on the main fabric, always make a sewing test on a small piece of the same fabric.
2. The blind hem foot is an optional accessory which is not supplied with your machine and you can buy it from your dealer.

Button Sewing:

Remove the zigzag foot .

Set the machine as illustrated and install the darning plate. (1)

Position the work under the presser foot holder. Place the button in the desired position, lower the presser foot lifter, this holds the button in place. Set pattern selector dial on zigzag stitch "B". Adjust the stitch width to "3" – "5" according to distance between the two holes of the button. Turn the handwheel to check that the needle enters into the left and right holes of the button.

Set the pattern selector dial on straight stitch "A", and sew a few securing stitches. Set the pattern selector dial on zigzag stitch "B", and slowly sew on the button with about 10 stitches. Set the pattern selector dial on straight stitch "A", and sew a few securing stitches. (2)

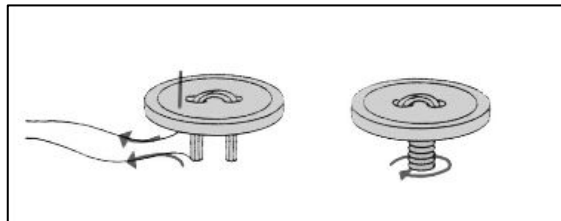
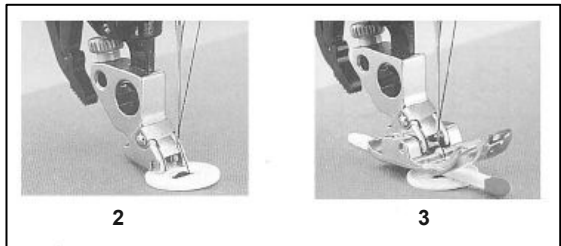
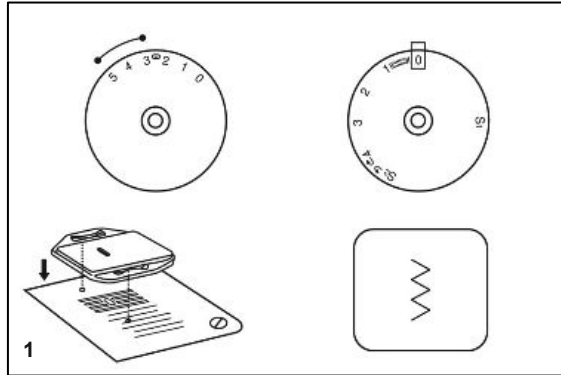

Note:

To sew 4 holes button: First sew the 2 front holes and pull the fabric forward, then sew the 2 rear holes as it was described in above.

Buttons with stems:

Insert the clear view foot. Release the foot holder but before you do so, place a match stick or darning needle on top of the button and sew a few zigzag stitches and leave the extra thread about 15 cm, then wrap the stem you have just created with the extra thread and knob the end of it.E.

Buttonholes Sewing:

Preparation:

Remove the zigzag foot and attach the buttonhole foot. Adjust the stitch length dial between “0.5” – “1”. The density of the stitch depends on thickness of the fabric.

To prepare the fabric:

Measure the diameter of the button and add 0.3 cm for the bartacks. If you have a very thick button, add more to the diameter measurement. Mark the position and length of the buttonhole on the fabric. Position the fabric so that the needles is on the mark that is furthest from you.

Pull the buttonhole foot towards you as far as it will go. Lower the foot.

a. Turn the pattern selector dial to “1”. Sew at moderate speed until you reach the end mark.

b. Turn the pattern selector dial to “2” and sew 5 to 6 bar tack stitches.

c. Turn the pattern selector dial to “3” and sew the left side of the buttonhole to the mark at the end which is further from you.

d. Turn the pattern selector dial to “4” and sew bar tack stitches.

Remove the fabric from under the foot. Draw the upper thread through the backside of the fabric and knot upper and lower threads. Cut the center of the buttonhole with the seam ripper, being careful not to cut the stitches on either side..

Tips:

- Slightly reduce upper thread tension to produce better results.
- Use backing material for fine and stretchy fabrics.
- It is advisable to use a gimp cord for stretch or knit fabrics. The zigzag should sew over the gimp. (e)

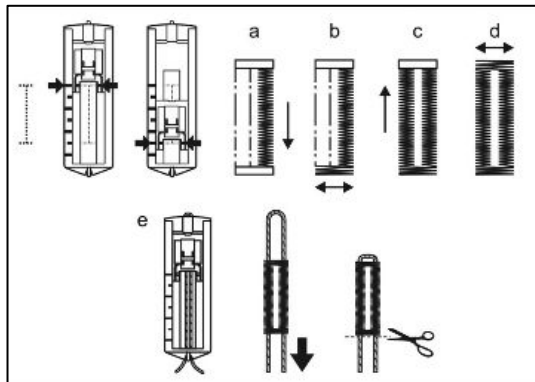
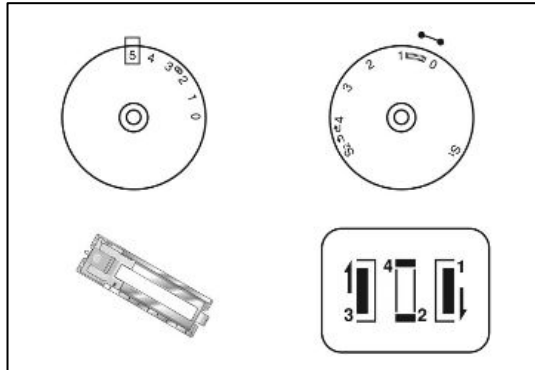

Sewing on Zipper:

Remove the zigzag foot and attach the zipper foot. Set pattern selector dial on straight stitch “A” and set stitch width dial in center needle position.

Adjust the stitch length dial between “1” – “4” (according to thickness of fabric).

Baste in the zipper by hand first. Push the zipper foot to the left as far as it will go. Place the open zipper under the foot so that its teeth run along the right guiding edge on the sole of the foot.

Sew about half the length of the zipper at the required width. Leave the needle down in the fabric, raise the zipper foot and close the zipper. Lower the zipper foot again, continue the seam and then sew across the end.

Sew the other side of the zipper at the same margin. Shortly before the end of the seam leave the needle down in the fabric, raise the zipper foot and open the zipper. Lower the zipper foot again and sew the end.

Note:

The zipper foot can be attached on either the right or left of needle, making it easy to sew both sides of the zipper.

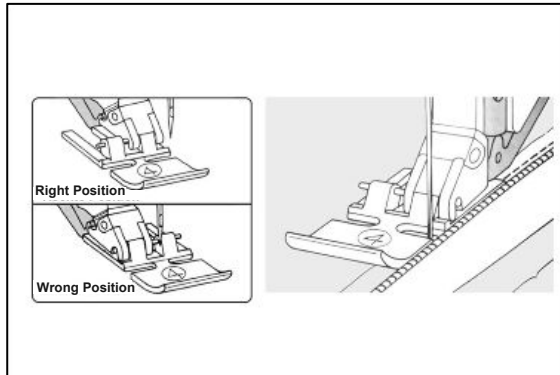
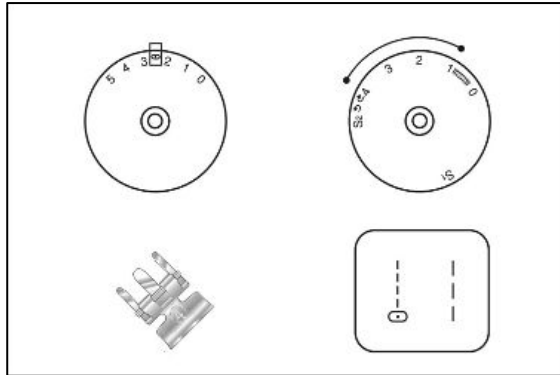

Sewing with the hemmer foot:

With the hemmer you can stabilize the edge of blouses, silk cravats and valance without having to iron the edges before hand. The hemming prevents the edges from fraying and produces a neat and durable edge finish. Remove the zigzag foot and attach the zipper foot. Set pattern selector dial on straight stitch "A" and set stitch width dial in center needle position.

The fabric to be hemmed must be clean and cut straight. At the beginning of the hem, double fold the fabric edge about 3 mm and place the folded fabric edge under the hemmer and sew 4-5 straight stitches to secure. Pull the thread slightly towards the back. Leave the needle in the fabric, raise the presser foot

and insert the fabric into the hemmer foot scroll.

Lower the presser foot and guide the fabric edge evenly into the hemmer. Take care to ensure that the fabric does not run underneath the right side of the presser foot.

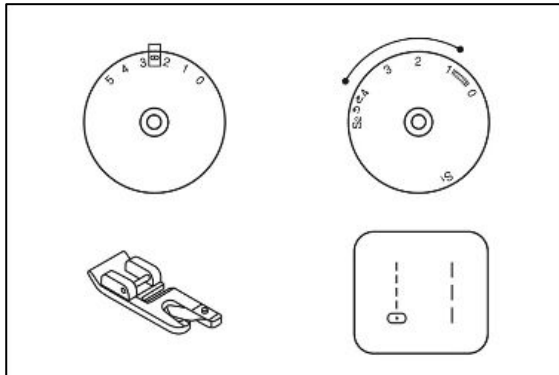

Attention:

On silk, viscose and chiffon fabrics, the roll hem is particularly attractive with a zigzag stitch.

Notes:

1. It takes a little practice to sew the rolled hems, therefore before you sew on the main fabric, always make a sewing test on a small piece of the same fabric.
2. The hemmer foot is an optional accessory which is not supplied with your machine and you can buy it from your dealer.

3 Steps zigzag stitch:

This stitch is used to sew on lace and elastic, darning, mending, reinforce edges. Turn the pattern stitch selection dial to “C” and set the machine as illustrated above.

Place patch in position. The stitch length can be shortened to produce very close stitches. (1)

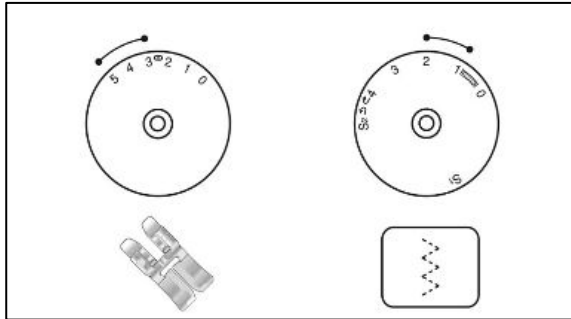

When mending tears, it is advisable to use a piece of backing fabric to reinforce. The stitch density can be varied by adjusting the stitch length. First sew over the center and then overlap on both sides. Depending on the type of fabric and damage, sew between 3 - 5 rows. (2)

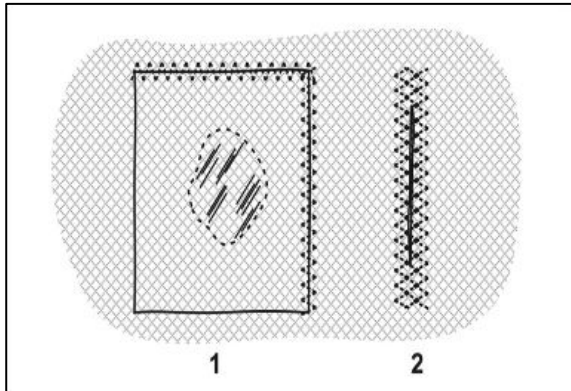

Sewing elastic

1. Place the elastic on the fabric.
2. As you sew, stretch the elastic both in the front and behind the presser foot.

Joining fabric

The elastic stitch can be used to join two pieces of fabric together and is very effective when sewing knitted fabrics. If nylon thread is used, the stitch will not be visible.

1. Place the edges of the two pieces of the fabric together and center them under the presser foot.
2. Sew them together using the elastic stitch taking care to keep the two fabric edges close together.

Darning:

Position the needle up and remove the presser foot and holder (2) and install the darning plate (1) .

Turn pattern selector dial to straight stitch “A” and set stitch width dial in center needle position.

Attach the darning foot to the presser bar. Push bar (a) to the back and hold it there. Fit (a) should be behind the needle clamp screw (b) .

Press the darning foot on firmly from behind with your index finger and tighten screw (c) . (3)

First sew a few stitches over the damaged area by guiding the fabric back and forth evenly while ensuring that each line ends with a small curve. This helps to avoid the fabric ripping again.

When the damaged area has been covered completely, rotate the fabric 90° and darn the area once again.

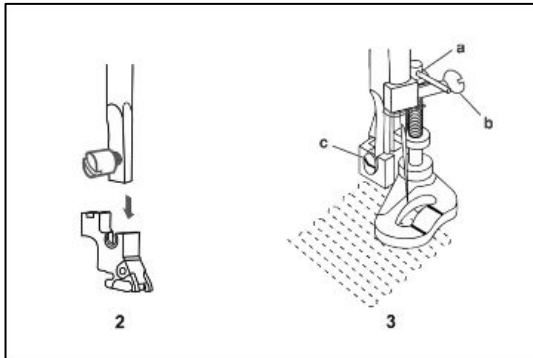
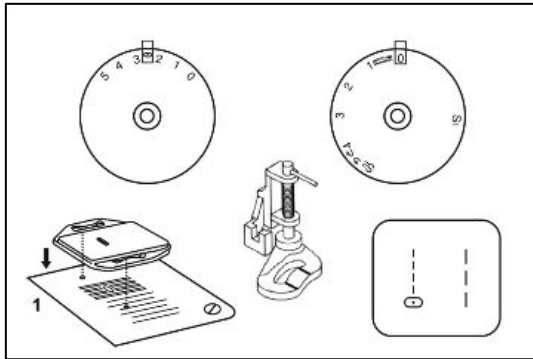

Note:
The hemmer foot is an optional accessory which is not supplied with your machine and you can buy it from your dealer.

Decorative stitches:

Set the machine as illustrated above.
Turn the stitch length dial to suit the fabric.

Shell stitch (A)

For decorative edges.
Suitable for edges on sheer, fine and stretch fabrics.
The larger stitch should go just over the edge of the fabric to create the shell effect.

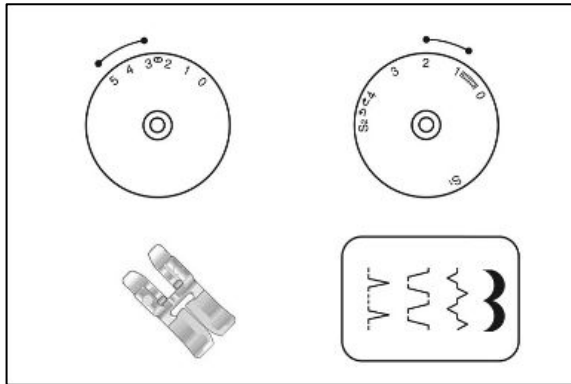

Greek stitch (B)

For flat joining seams,
sewing on elastic, visible hems.
This stitch can be used for firm, thicker fabrics.

Bridging stitch (C)

For seams, place mats,
tablecloths.
Decorative joining seam for a fagoted effect. Gathering with cord or shirring elastic.

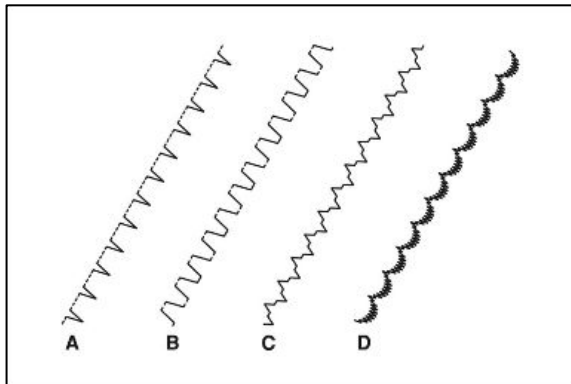

Crescent stitch (D)

For a delicate edge finish along the edge of fabric.
This stitch looks best with a stitch length set between "0.5" to "1".

Couching:

Turn the pattern stitch selection dial to “B” and set the machine as illustrated above.

The stitch length and width are variable and set stitch width according to width of cord. (1)

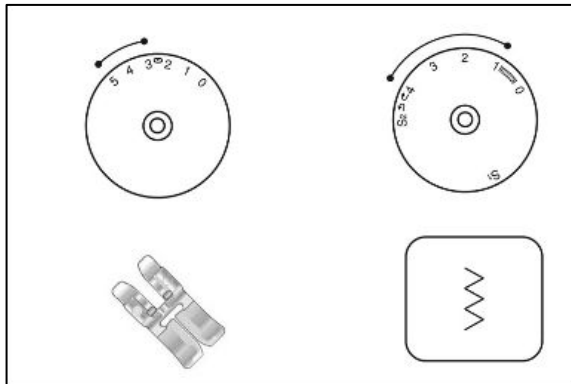

Sewing instruction:

Couching is simply technique of zigzag stitch over fine cords, wool threads, etc. This gives your jackets or other clothing a very special touch.

With a marking pencil, draw a design on your fabric.

Lay the cord under the center opening of your foot and zigzag over the cord so that the needle falls just to the right and left of decorative cord.

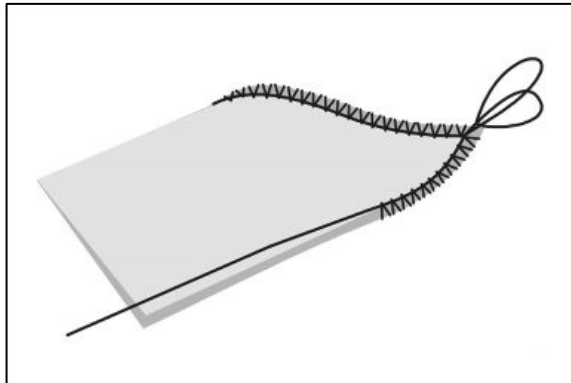

As you sew, follow the lines of your design.

Twin Needle:

- Select the desired stitch length by rotated the stitch length dial.
- Turn stitch selector dial to straight stitch and set the stitch width dial in center needle position.
- For twin needle sewing, place second thread on other spool pin.
- Make sure that the two threads used to thread the twin needle are the same weight. You can use one or two colors.
- Insert the twin needle in the same way as single needle. Flat side of needle should face away from you.
- Follow instructions for single needle threading. Thread each needle separately.

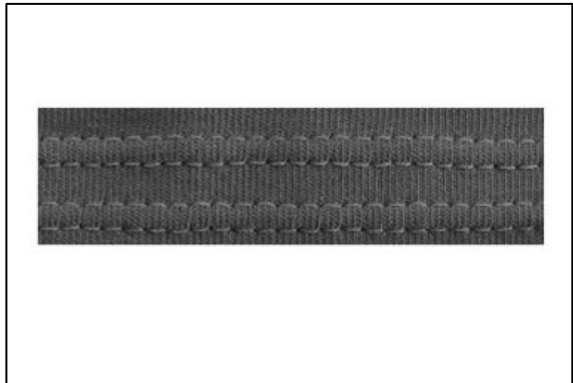
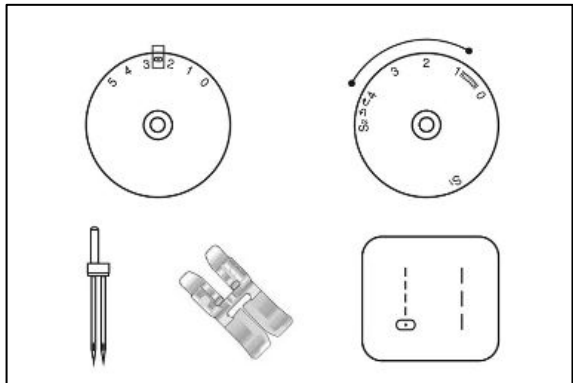

Notes:

1. Always sew slowly when sewing with a twin needle for a high quality seam. Use a stitch width only from "0" to "3" for zigzag stitches, do not use a setting of "3" or above for twin needle.
2. The twin needle is an optional accessory which is not supplied with your machine and you can buy it from your dealer.

Monogramming and embroidering with embroidery hoop:

- Remove the presser foot and holder and install the darning plate.
- Set the machine as illustrated above.
- Lower presser foot lever before starting to sew.
- Adjust the stitch width according to the size of lettering or design.

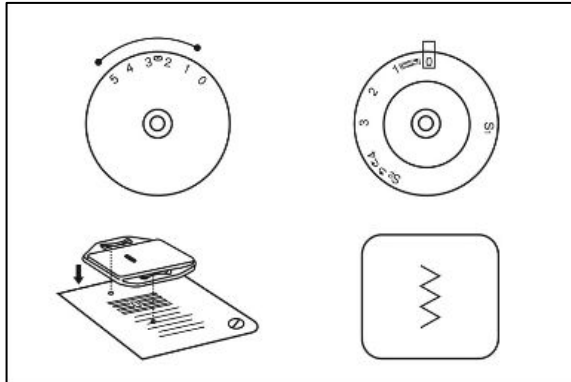

Preparation for monogramming and embroidering:

- Draw the desired lettering or design on the right side of the fabric.
- Stretch the fabric between embroidery hoop as firmly as possible.
- Place the fabric under the needle. Make sure the presser foot bar is down in its lowest position.
- Turn the balance wheel towards you to bring up the lower thread through the fabric. Sew a few securing stitches at the starting point.
- Hold the hoop with thumb and forefingers of both hands while pressing the material with the middle and ring fingers and supporting the outside of hoop with smaller finger .

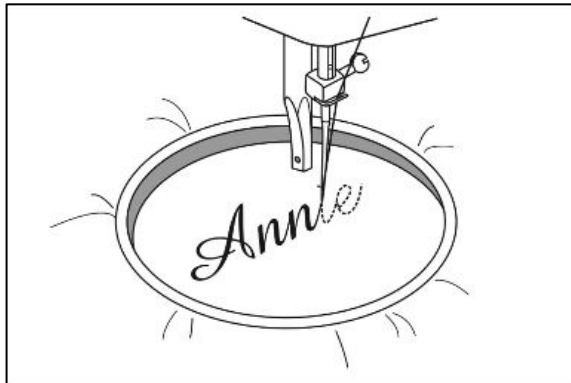

Note:

The embroidery hoop is an optional accessory which is not supplied with your machine and you can buy it from your dealer.

Monogramming and embroidering with embroidery hoop:

Monogramming:

1. Sew while moving the hoop slowly along the lettering at a constant speed.
2. Secure with a few straight stitches at the end of the last letter..

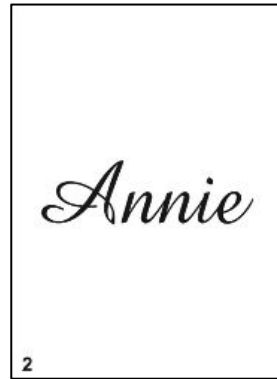
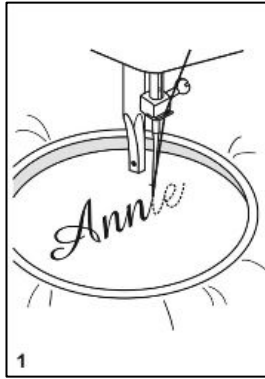

Embroidering

1. Stitch the outline of the design by moving the embroidery hoop.
2. Fill in the design working from the outline of the design to the inside and from the inside to the edge of the outline until the design is completely filled in. Keep the stitching close together.
A long stitch is made by moving the hoop rapidly and a short stitch is made by moving it slowly.
3. Secure with a few straight stitches at the end of the design

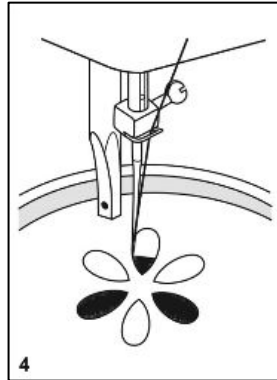
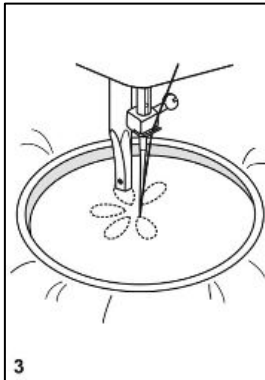

Maintenance:



Disconnect the machine from electricity supply by removing the plug from mains socket. When cleaning the machine, it must always be disconnected from electricity supply.

Remove the stitch plate (1):

Turn the handwheel until the needle is fully raised. Open the hinged front cover and unscrew the needle plate screws with the screw driver.

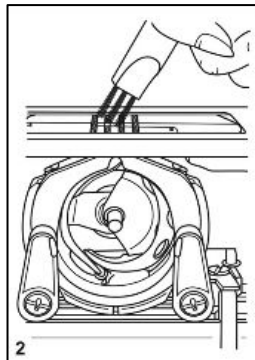
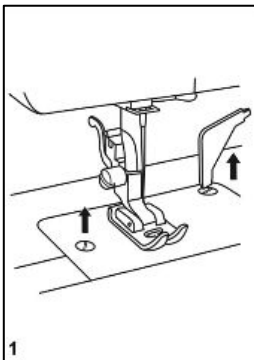

Cleaning the feed dogs (2):

Remove the bobbin case and use the brush supplied to clean the whole area.

Cleaning and lubricating the hook (3):

Remove the bobbin case. Snap the two hook retaining arms (a) outwards. Remove the hook race cover (b) and the hook (c) and clean with a soft cloth. Lubricate at the point (d) (1 -2 drops) with sewing machine oil. Turn the handwheel until the hook race (e) is in the left position. Replace the hook (c). Replace the hook race cover and snap back the two hook retaining arms. Insert the bobbin case and bobbin and replace the needle plate.

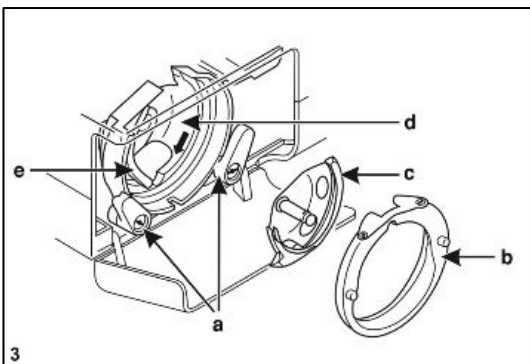

Important:

Fabric lint and threads must be removed regularly. In addition, the sewing machine must be serviced at regular intervals at one of our customer service centers. The housing can be cleaned from dust with a clean and soft cloth which is free of fluff. To remove any of stubborn dirt, use a soft cloth with alcohol. Do not use any insecticides or chemical products such as petrol (gasoline) or thin chemicals for cleaning the housing.

Storage:

Unplug the power cord when you are not using the machine. For storage, pull out the plug of the foot control and cover the machine with the supplied carrying case.

Trouble shooting guide

Problem	Cause	correction
The needle (upper) thread breaks	<ol style="list-style-type: none"> 1. The machine is not threaded properly. 2. The thread tension is too tight. 3. The thread is too thick for the needle. 4. The needle is incorrectly inserted. 5. The thread is wound around the spool holder pin. 6. The needle is bent or blunt. 	<ol style="list-style-type: none"> 1. Rethread the machine. 2. Reduce the thread tension (lower number). 3. Select a larger needle. 4. Remove and insert the needle (flat side must towards the back). 5. Remove the reel and wind thread onto reel. 6. Replace the needle.
The bobbin (lower) thread breaks	<ol style="list-style-type: none"> 1. The bobbin case is not inserted correctly. 2. The bobbin case is threaded wrong. 3. The lower thread tension is too tight. 	<ol style="list-style-type: none"> 1. Remove and reinsert the bobbin case and pull on the read. The thread should pull easily. 2. Check both bobbin and bobbin case. 3. Loosen lower tension as described.
Skipped stitches	<ol style="list-style-type: none"> 1. The needle is incorrectly inserted. 2. The needle is damaged. 3. The wrong size or type of needle has been used. 4. The foot is not attached correctly. 	<ol style="list-style-type: none"> 1. Remove and insert the needle (flat side must towards the back). 2. Insert a new needle. 3. choose a needle to suit the thread and fabric. 4. Check and attach correctly.
Needle breaks	<ol style="list-style-type: none"> 1. The needle is damaged. 2. The needle is not correctly inserted. 3. Wrong needle size for the fabric. 4. The wrong foot is attached. 	<ol style="list-style-type: none"> 1. Insert a new needle. 2. Insert the needle correctly(flat side must towards the back). 3. choose a needle to suit the thread and fabric. 4. Select the correct foot.

Trouble shooting guide

Problem	Cause	correction
Loose stitches	<ol style="list-style-type: none"> 1. The machine is not correctly threaded. 2. The bobbin case is not correctly threaded. 3. Needle/ fabric / thread combination is wrong. 4. Thread tension wrong. 	<ol style="list-style-type: none"> 1. Check the threading. 2. Thred the bobbin case as described. 3. The needle size must suit the thread and fabric. 4. Correct the thread tension.
Seams gather or pucker	<ol style="list-style-type: none"> 1. The needle is too thick for the fabric. 2. The stitch length is incorrectly adjusted. 3. The thread tension is too tight. 	<ol style="list-style-type: none"> 1. Select a finer needle. 2. Readjust the stitch length. 3. Loosen the thread tension.
Uneven stitches and uneven feed	<ol style="list-style-type: none"> 1. Poor quality thread. 2. The bobbin case is incorrectly threaded. 3. Fabric has been pulled. 	<ol style="list-style-type: none"> 1. Select a better quality thread. 2. Remove bobbin case, thread and insert correctly. 3. Do not pull on the fabric while sewing, let it be taken up by the machine.